

Hotplate HP-160

The SAWATEC HP-160 hotplate has been developed for standard soft bake and hard bake processes in lithography and similar applications. The temperature range is designed as standard up to 250° C. The HP-160 offers high uniformity and process repeatability and can be used for substrates up to 150mm.

Outstanding features of the hotplate are its robust design and ease of operation. The hotplate's modular design means that it can be used in a wide range of applications with high optional expandability (wet bench integration).



FEATURES:

- ↗ Digital temperature controller with actual- and nominal value
- ↗ Max. substrate size 150mm
- ↗ Heating ramp up possible with 20 steps
- ↗ Pneumatic lift of the lid
- ↗ Internal height max. 23mm max. substrat thickness 20mm (without protective glass and proximity pins)
- ↗ Substrate loading: manual
- ↗ Substrat fixation via vacuum manual controlled
- ↗ Accuracy of temperature: +/-1°C per 100°C

Tel: +423 377 17 90
 Fax: +423 377 17 91
 sales@sawatec.com
 www.sawatec.com

SAWATEC AG
 Industriestrasse 56
 Postfach 514
 FL-9491 Ruggell

For further information please contact our sales-department: sales@sawatec.com

Pictures may show standards with options.

OPTIONS

- ⇒ Nitrogen flush controlled
 - N2-lid made of anodised aluminium
 - N2 solenoid valve
- ⇒ Proximity as well as loading pins
 - Pneumatic driven pins (stroke 8mm)
 - Manual adjustable proximity pins between 0-1mm (0.1mm increments)
 - Pin made of Inconel with Ceramicball
 - Pin-circel-diameter Ø 45mm
- ⇒ Protection glass without pins
- ⇒ Protection glass with proximity pins

N2-LID

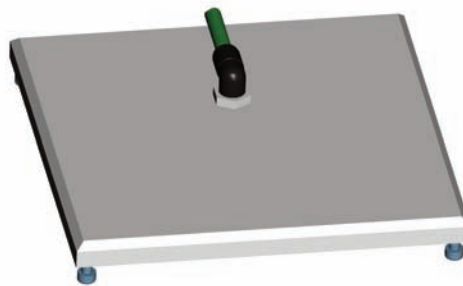

PROTECTION GLASS

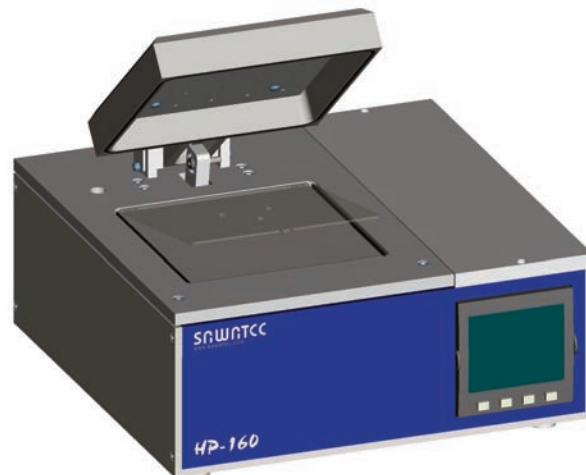

PROXIMITY PINS

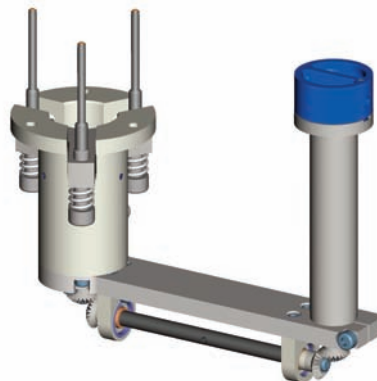

- ↔ Temperature range: 25 - 250°C
- ↔ Accuracy of temperature: +/-1°C bei 100°C
- ↔ Substrate loading: manual
- ↔ Substrat fixation via vacuum
- ↔ Max. substrate size 150mm

- ↔ 240 VAC 50/60Hz (1200 W)
- ↔ Technical vacuum, tube Ø6/4mm
- ↔ Exhaust connector Ø32mm
- ↔ Compressed air 4 bar, tube Ø6/4mm

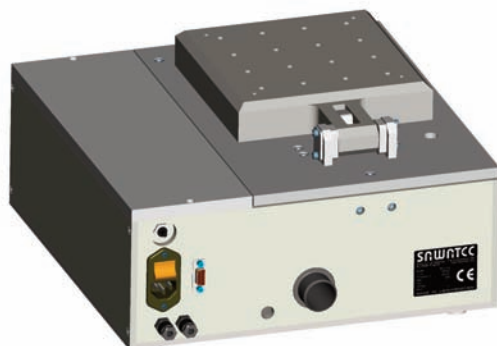

For further information please contact our sales-department: sales@sawatec.com

Pictures may show standards with options.

PERFORMANCE

REQUIRED MEDIA

Tel: +423 377 17 90
Fax: +423 377 17 91
sales@sawatec.com
www.sawatec.com

SAWATEC AG
Industriestrasse 56
Postfach 514
FL-9491 Ruggell

VIEWS

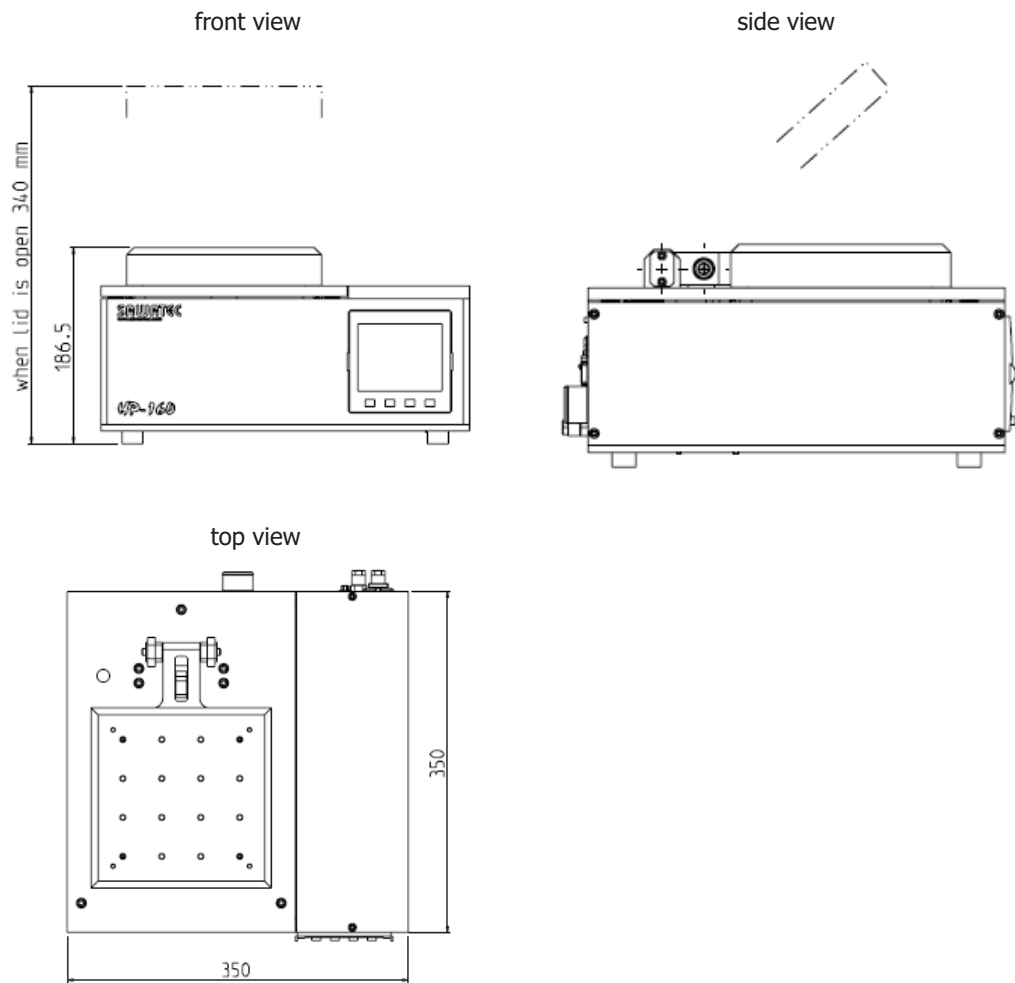

DIMENSIONS

- ⇒ Size: 350x350x190mm (LxBxH)
- ⇒ Hotplate size: 160x160mm
- ⇒ Weight: approx. 18kg

DESIGN

- ⇒ Housing: Anodised aluminium
- ⇒ Hotplate material: Anodised aluminium

DEALER

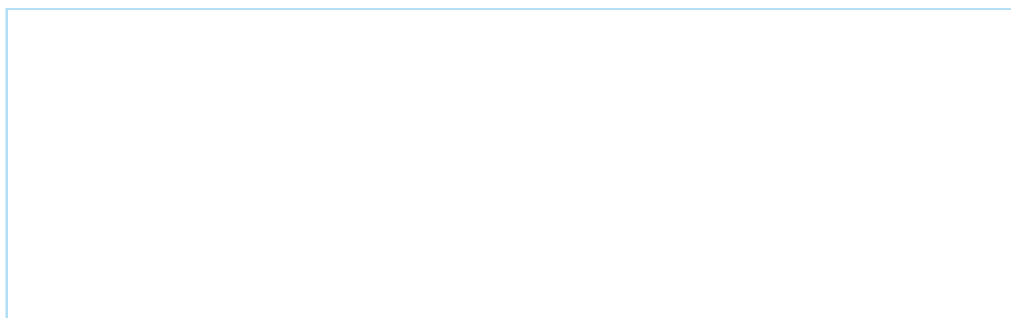

Tel: +423 377 17 90
 Fax: +423 377 17 91
 sales@sawatec.com
 www.sawatec.com

SAWATEC AG
 Industriestrasse 56
 Postfach 514
 FL-9491 Ruggell

For further information please contact our sales-department: sales@sawatec.com

Pictures may show standards with options.