

Hotplate HP-200-Z-HMDS Cabinet

The SAWATEC HP-200-Z-HMDS hotplate has been developed for standard soft bake and hard bake processes in lithography and similar applications. The multi-zone heating system (9 zones) ensures very high temperature distribution, which is adjustable for each zone. The hotplate also has a vacuum chamber and can be used as standard for bonding agent applications.

The temperature range is designed as standard up to 300° C. The HP-200-Z-HMDS offers very high uniformity and process repeatability and can be used for substrates up to 200mm.

Outstanding features of the hotplate are its robust design and ease of operation. The hotplate's modular design means that it can be used in a wide range of applications with high optional expandability.



HP-200-Z-HMDS

FEATURES:

- ↗ Hotplate/Coolplate is divided into 9 zones
- ↗ Max. substrate size 200mm
- ↗ Substrate loading: manual
- ↗ Substrate fixation via vacuum
- ↗ Accuracy of temperature: +/-0,3°C per 100°C
- ↗ PLC controller with touch panel 5,7" monochrome
- ↗ Max. 20 segments per program
- ↗ Pneumatic lift of the lid
- ↗ Internal height max. 18mm max. substrate thickness 15mm
- ↗ Free programmable temp. ramp up with max. 10°C/min (25°-300°C)
- ↗ Free programmable temp. ramp down with max. 5°C/min (300°-40°C)

Tel: +423 377 17 90
 Fax: +423 377 17 91
 sales@sawatec.com
 www.sawatec.com

SAWATEC AG
 Industriestrasse 56
 Postfach 514
 FL-9491 Ruggell

For further information please contact our sales-department: sales@sawatec.com

Pictures may show standards with options.

OPTIONS

⇒ Protection glass

PROTECTION GLASS

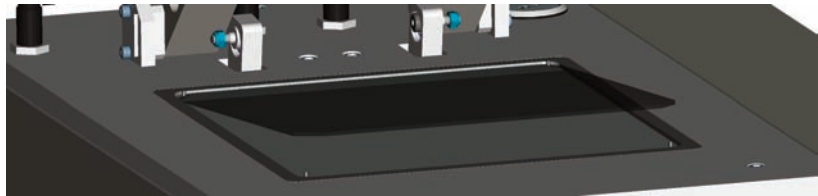

- ↔ Temperature range: 25 - 300°C
- ↔ Accuracy of temperature: +/-0,3°C per 100°C
- ↔ Substrate loading: manual
- ↔ Substrate fixation via vacuum
- ↔ Max. substrate size 200mm
- ↔ Internal height max. 18mm: max. substrate thickness 15mm

- ↔ 3x400VAC +P 50/60Hz (3,6kW)
- ↔ Technical vacuum, tube Ø6/4mm
- ↔ Exhaust-connector Ø 76mm
- ↔ Compressed air 4 bar, tube Ø6/4mm
- ↔ N2-connector, tube Ø6/4mm
- ↔ HMDS-connector, tube Ø6/4mm
- ↔ Cooling water 3l/min by 18°C
- ↔ Cooling water In/Out, tube Ø8/6mm (2pcs.)

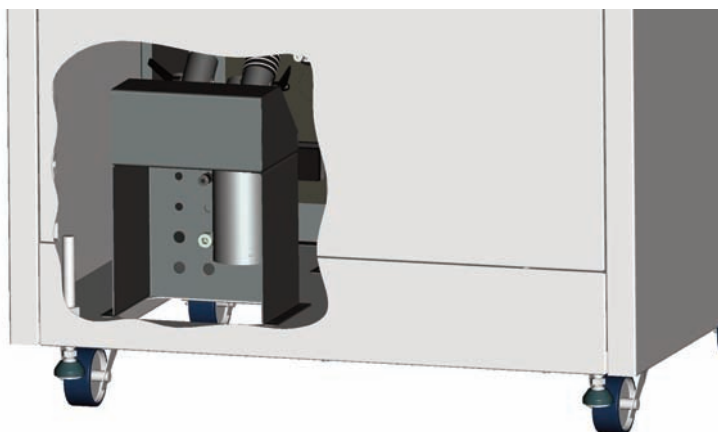

For further information please contact our sales-department: sales@sawatec.com

Pictures may show standards with options.

PERFORMANCE

REQUIRED MEDIA

Tel: +423 377 17 90
 Fax: +423 377 17 91
sales@sawatec.com
www.sawatec.com

SAWATEC AG
 Industriestrasse 56
 Postfach 514
 FL-9491 Ruggell

VIEWS

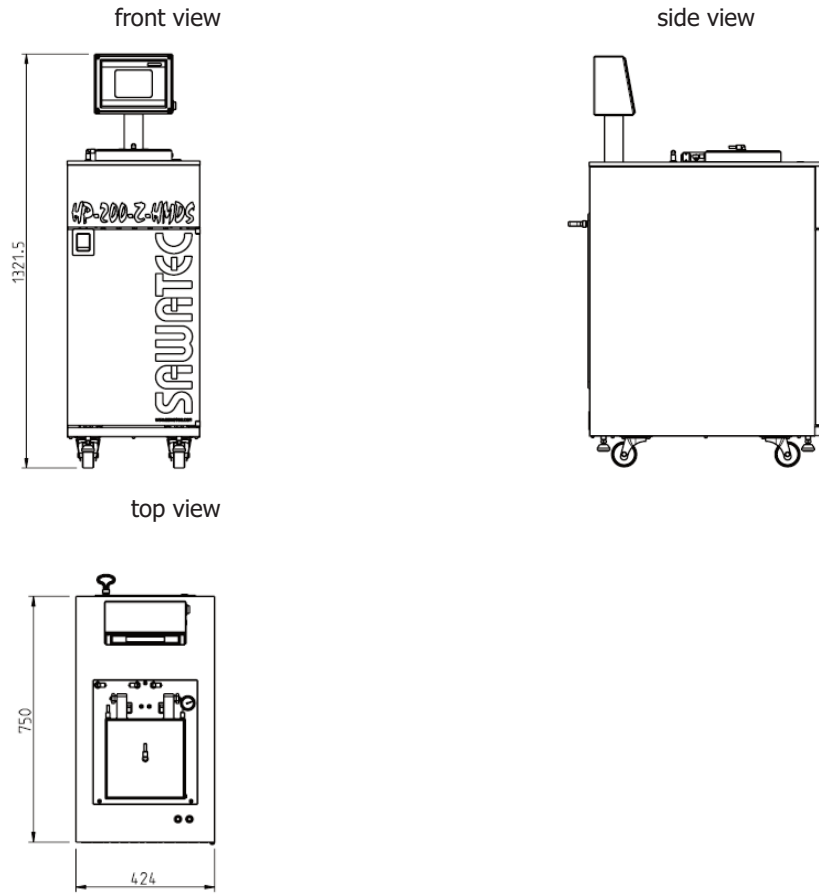

DIMENSIONS

- ⇒ Size: 424x750x1320mm (LxBxH)
- ⇒ Hotplate size: 210x210mm
- ⇒ Weight: approx. 75kg

DESIGN

- ⇒ Housing: Stainless steel frame
- ⇒ Hotplate material: Anodised aluminium

DEALER

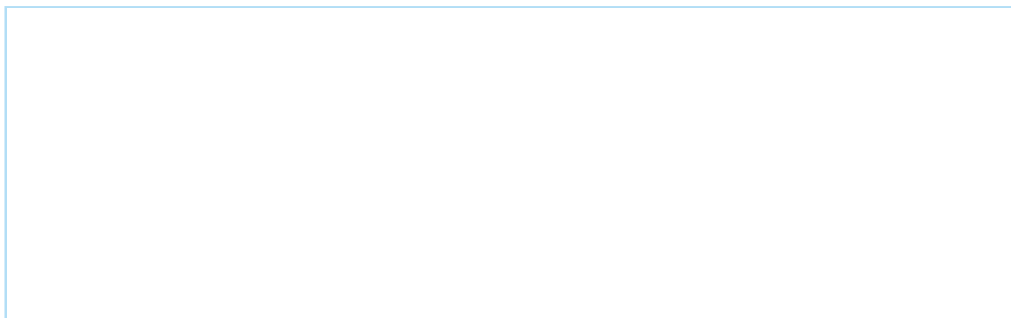

Tel: +423 377 17 90
 Fax: +423 377 17 91
 sales@sawatec.com
 www.sawatec.com

SAWATEC AG
 Industriestrasse 56
 Postfach 514
 FL-9491 Ruggell