

Hotplate HP-401-Z Cabinet

The SAWATEC HP-401-Z hotplate has been developed for standard soft bake and hard bake processes in lithography and similar applications. The multi-zone heating system (16 zones) ensures very high temperature distribution, which is adjustable for each zone.

The temperature range is designed as standard up to 300° C. The HP-401-Z offers very high uniformity and process repeatability and can be used for substrates up to 300mm.

The hotplate comes as standard with proximity pins and loading pins, allowing simultaneous processing of five substrates (up to 100mm).

Outstanding features of the hotplate are its robust design and ease of operation. The hotplate's modular design means that it can be used in a wide range of applications with high optional expandability.



HP-401-Z

FEATURES:

- ↗ Hotplate/Coolplate is divided into 16 zones
- ↗ PLC controller with touch panel 5,7" monochrome
- ↗ max. 20 segments per program
- ↗ Pneumatic lift of the lid
- ↗ Pneumatic driven loading as well as proximity pins
- ↗ Manual adjustable proximity pins between 0-1mm (0.1mm increments)
- ↗ Pin made of Inconell with ceramicball
- ↗ Pin-circle-diameter Ø45mm
- ↗ Internal height max. 23mm max.substrate thickness 20mm
- ↗ Max. substrate size 1x300mm or 5x100mm
- ↗ Substrate loading: manual
- ↗ Substrate fixation via vacuum
- ↗ Free programmable temp. ramp up with max. 10°C/min (25°-300°C)
- ↗ Free programmable temp. ramp down with max. 5°C/min (300°-40°C)

Tel: +423 377 17 90
 Fax: +423 377 17 91
 sales@sawatec.com
 www.sawatec.com

SAWATEC AG
 Industriestrasse 56
 Postfach 514
 FL-9491 Ruggell

For further information please contact our sales-department: sales@sawatec.com

Pictures may show standards with options.

HP-401-2

OPTIONS

- ⇒ Nitrogen flush PLC controlled
 - N2-lid made anodised aluminium
 - N2 solenoid valve
- ⇒ Protection glass with pins
- ⇒ Nitrogen- and HMDS prime PLC controlled
 - N2-lid made anodised aluminium
 - N2 solenoid valve
 - HMDS solenoid valve

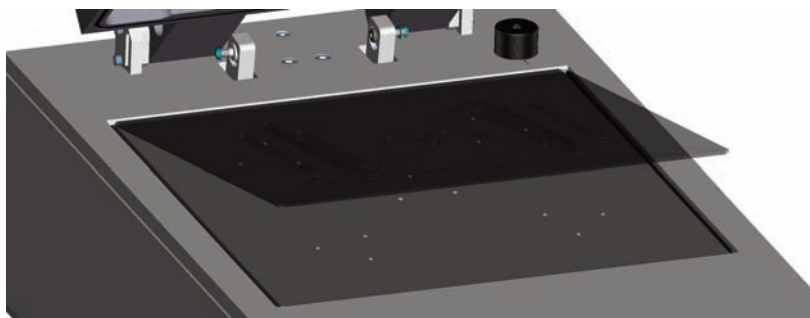

PROTECTION GLASS

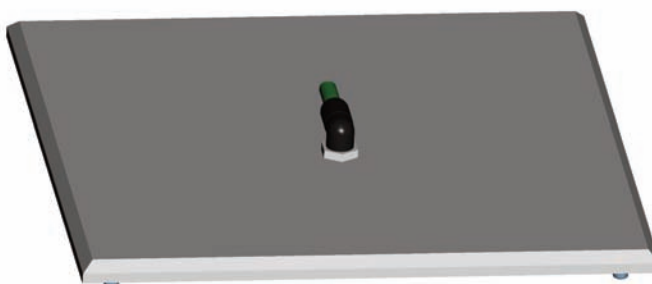

N2-LID

- ⇒ Temperature range: 25 - 300°C
- ⇒ Accuracy of temperature: +/-0,3°C per 100°C
- ⇒ Substrate loading: manual
- ⇒ Substrat fixation via vacuum
- ⇒ Max. substrate size 1x300mm or 5x100mm
- ⇒ Internal height max. 23mm: max. substrat thickness 20mm

- ⇒ 3x400 VAC 50/60Hz (8kW)
- ⇒ Technical vacuum, tube Ø6/4mm
- ⇒ Compressed air 4 bar, tube Ø6/4mm
- ⇒ Exhaust-connector Ø76mm
- ⇒ Cooling water 3l/min by 18°C
- ⇒ Cooling water In/Out, tube Ø8/6mm

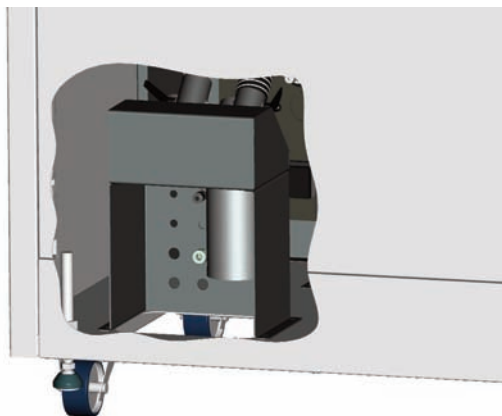

For further information please contact our sales-department: sales@sawatec.com
 Pictures may show standards with options.

PERFORMANCE

REQUIRED MEDIA

Tel: +423 377 17 90
 Fax: +423 377 17 91
sales@sawatec.com
www.sawatec.com

SAWATEC AG
 Industriestrasse 56
 Postfach 514
 FL-9491 Ruggell

VIEWS

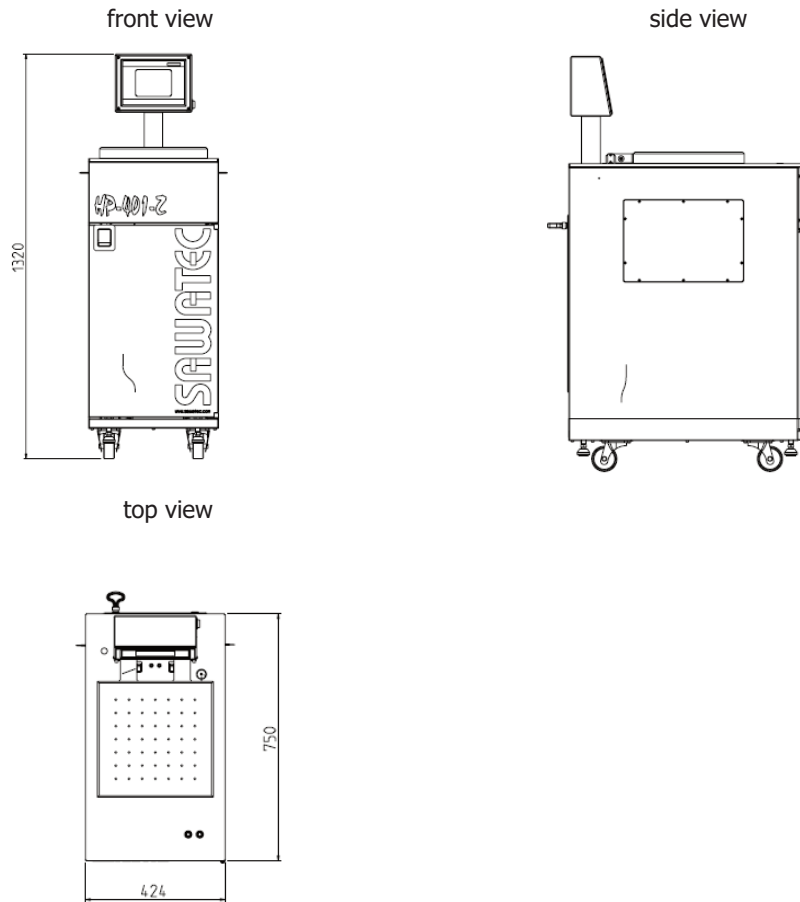

DIMENSIONS

- ⇒ Size: 424x750x1320mm (LxBxH)
- ⇒ Hotplate size: 320x320mm
- ⇒ Weight: ca. 80kg

DESIGN

- ⇒ Housing: Stainless steel frame
- ⇒ Hotplate material: Anodised aluminium

DEALER

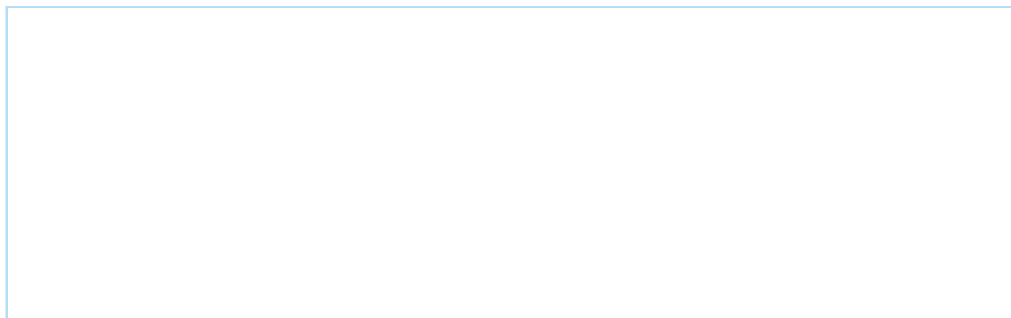

Tel: +423 377 17 90
 Fax: +423 377 17 91
 sales@sawatec.com
 www.sawatec.com

SAWATEC AG
 Industriestrasse 56
 Postfach 514
 FL-9491 Ruggell

For further information please contact our sales-department: sales@sawatec.com

Pictures may show standards with options.