

Spin Coater LSM-600

The instruments of the SAWATEC-LSM-line are easy to operate and to handle. The LSM-600 is available as Cabinet-version. It is designed to coat substrates up to 15" x 16" . The process-chamber works up to Ø 600mm.

The spin module of SAWATEC AG will convince you of high uniformity and repeatability combined with easy handling.

For pilot projects, institutes, research and development.



FEATURES:

- ⇒ Stainless steel made bowl assembly is capable up to 600mm
- ⇒ Processcontroller with touch panel 5,7" monochrom.
- ⇒ Processparameter: speed (rpm), acceleration, time (s), dosingtime (s)
- ⇒ Start of process by start button or touch panel
- ⇒ Up to 50 recipes (24 segments per recipe)
- ⇒ Closed process chamber with cover made of stainless steel, adjustable distance between cover and substrate
- ⇒ Dispensing pump SP-50 for viscosities up to 800 cps. incl. suck back function
- ⇒ Control elements for compr. air and vacuum for dispensing included
- ⇒ Substrate loading: manual
- ⇒ Substrate fixation via vacuum and safety interlock protection
- ⇒ Acoustic alarm when process has finalized

Tel: +423 377 17 90
 Fax: +423 377 17 91
 sales@sawatec.com
 www.sawatec.com

SAWATEC AG
 Industriestrasse 56
 Postfach 514
 FL-9491 Ruggell

For further information please contact our sales-department: sales@sawatec.com

Pictures may show standards with options.

LSM-600

OPTIONS

- ⇒ Additional dispense line with dosing pump
- ⇒ Footswitch (Cablelength 1.8m)
- ⇒ Manual nitrogene purge

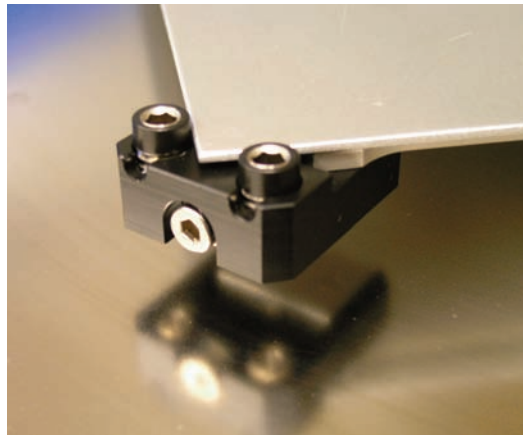

CHUCKS

- ⇒ Vacuum chuck 14"x16"
- ⇒ More chucks on request

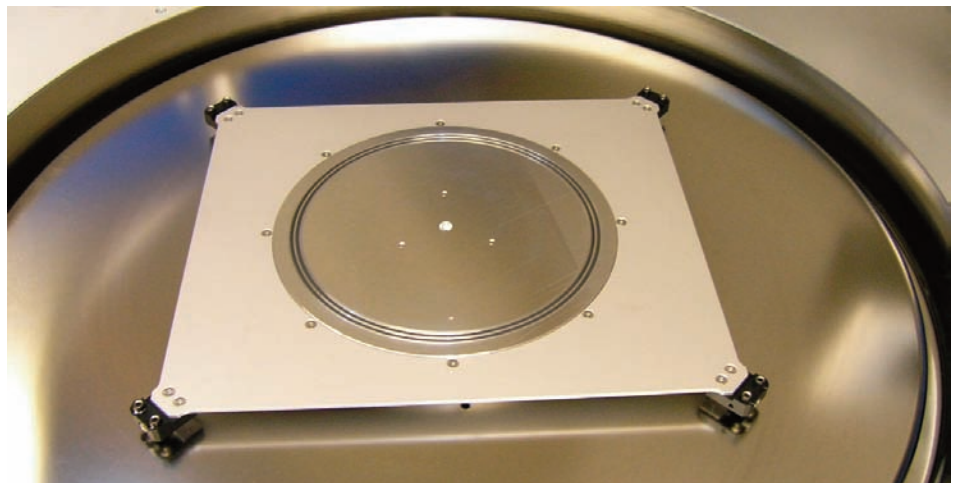

For further information please contact our sales-department: sales@sawatec.com
Pictures may show standards with options.

PERFORMANCE

- ⇒ Max speed: 2'000rpm +/-1rpm
- ⇒ Acceleration: 1-5'000 rpm/s unloaded
programmable start and stop position
- ⇒ Processparameter: speed 2'000rpm
acceleration 160rpm/sec²
time 2376sec
dosingtime 99sec
- ⇒ Recipes: up to 50 (depends on the size of
each recipe)
- ⇒ Segments: max. 24 segments
- ⇒ Dispensing pump SP-50 for viscosities up to 800 cps. incl. suck back function

- ⇒ 240VAC 50/60Hz 15A
- ⇒ Plugconnector for foot switch
- ⇒ Technical vacuum, tube Ø6/4mm (-0.8bar)
- ⇒ Compressed air, tube Ø6/4mm (6bar)
- ⇒ Exhaust-connector Ø76mm (40-60m³/h)

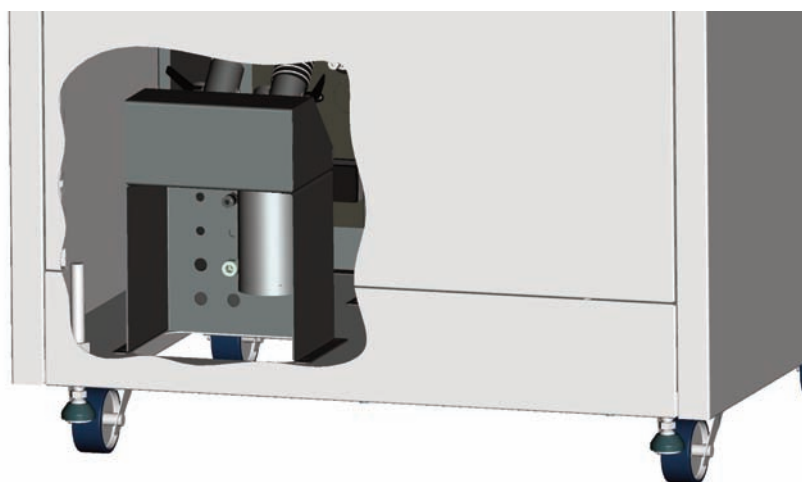

For further information please contact our sales-department: sales@sawatec.com
Pictures may show standards with options.

REQUIRED MEDIA

Tel: +423 377 17 90
Fax: +423 377 17 91
sales@sawatec.com
www.sawatec.com

SAWATEC AG
Industriestrasse 56
Postfach 514
FL-9491 Ruggell

VIEWS

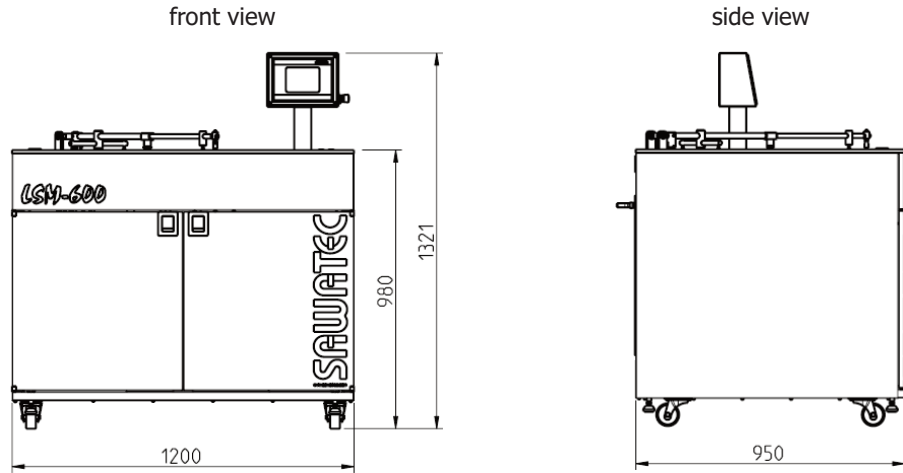

top view

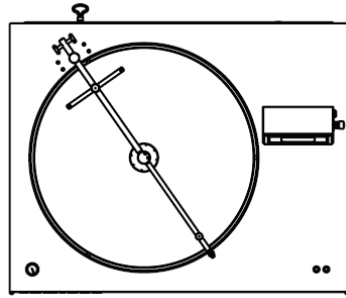

DIMENSIONS

- ↪ Size: 1200x950x980 (LxBxH)
- ↪ Weight: approx. 160kg

DESIGN

- ↪ Housing: Stainless steel
- ↪ Processbowl: Stainless steel
- ↪ Splash-collar: Stainless steel
- ↪ Lid: Stainless steel

DEALER

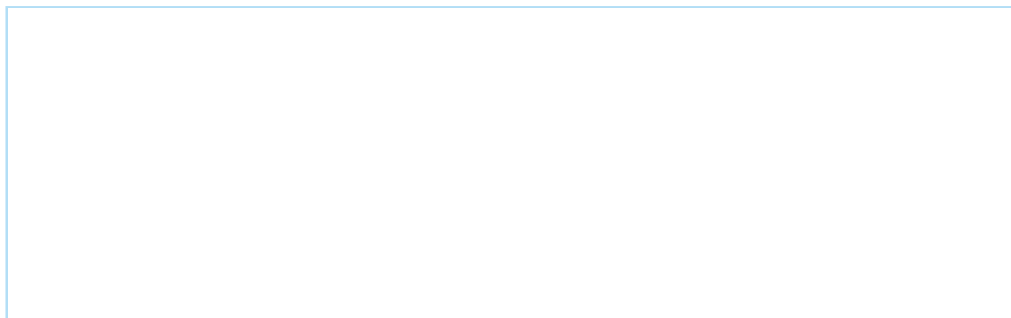

Tel: +423 377 17 90
 Fax: +423 377 17 91
 sales@sawatec.com
 www.sawatec.com

SAWATEC AG
 Industriestrasse 56
 Postfach 514
 FL-9491 Ruggell