

Spin Coater LSM-300

The instruments of the SAWATEC-LSM-line are easy to operate and to handle. The instruments of this line are available as bench-mounted- or cabinet-version. They are designed to coat wafers up to 12" or substrates up to 8" x 8" (200 x 200mm). The process-chamber works up to Ø 300mm.

The spin-module of SAWATEC AG will convince you of high uniformity and repeatability combined with easy handling.

For pilot projects, institutes, research and development.



LSM-300

FEATURES:

- ⇒ Anodised aluminium made bowl assembly is capable up to 12" or 8"x8" (300mm)
- ⇒ Easy change of chuck typ, without any tools
- ⇒ Processcontroller with touch panel 5,7" monochrom
- ⇒ Processparameter: speed(rpm), acceleration, time(sec.), dosingtime(sec.)
- ⇒ Start of process by start button or touch panel
- ⇒ Up to 50 recipes (24 segments per recipe)
- ⇒ Closed process chamber with cover made of glass, adjustable distance between cover and substrate
- ⇒ Bowl protection ring selectable
- ⇒ Pneumatic driven dispensearm with home and dosing position
- ⇒ Dosing system selectable
- ⇒ Control elements for compr. air and vacuum for dispensing included
- ⇒ Substrate loading: manual
- ⇒ Substrate fixation via vacuum and safety interlock protection
- ⇒ Acoustic alarm when process has finalized

Tel: +423 377 17 90
 Fax: +423 377 17 91
 sales@sawatec.com
 www.sawatec.com

SAWATEC AG
 Industriestrasse 56
 Postfach 514
 FL-9491 Ruggell

For further information please contact our sales-department: sales@sawatec.com

Pictures may show standards with options.

OPTIONS

- ⇒ Semi automatic cartridge dispensing system, 50ml glass syringe
- ⇒ External cartridge dispensing system (pillar-holder), 50ml glass syringe
- ⇒ Dynamic dispensarm for dynamic and static dispensing function
- ⇒ Top side edge bead removal EBR with SP-177
- ⇒ Dispensumpump SPV-15 for high viskositities
- ⇒ Additional dispense line with dosing pump
- ⇒ Wafer alignment 2" - 8" (round)
- ⇒ Footswitch (Cablelength 1.8m)
- ⇒ Two piece bowl protection made of PE (set of 10pcs.)
- ⇒ Polypropylen made bowl assembly
- ⇒ Stainless steel made bowl assembly
- ⇒ Hood for processchamber made of PET

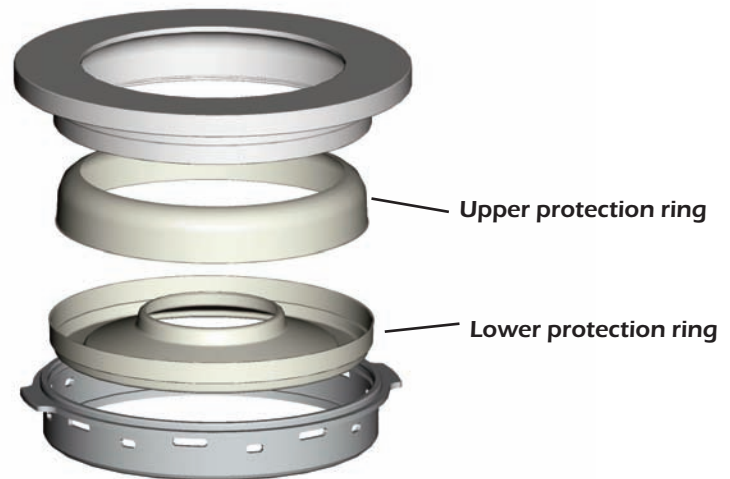

Sample for two pices bowl protection made of PE

CHUCKS

- ⇒ Vakuüm chuck 2" bis 3" round
- ⇒ Vakuüm chuck 100mm (4") per 300mm (12")
- ⇒ Vakuüm chuck 100x100mm (4"x4")
- ⇒ Vakuüm chuck 125x125mm (5"x5")
- ⇒ Vakuüm chuck 150x150mm (6"x6")
- ⇒ Vakuüm chuck 200x200mm (8"x8")
- ⇒ More chucks on request

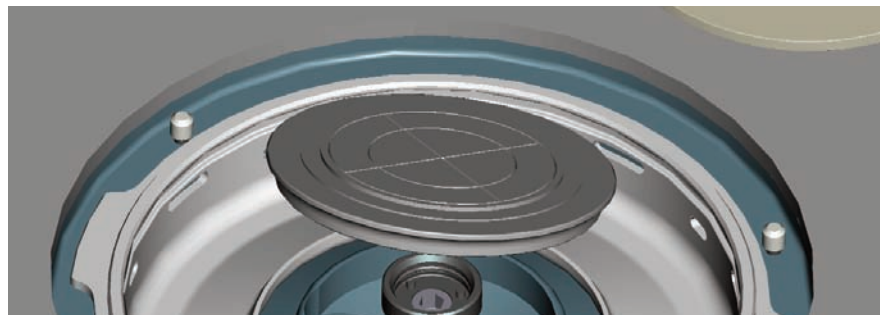

For further information please contact our sales-department: sales@sawatec.com

Pictures may show standards with options.

PERFORMANCE

- ⇒ Max. speed: 6'000rpm +/-1rpm
- ⇒ Processparameter: speed 6'000rpm
acceleration 160rpm/sec²
time 2376sec
dosingtime 99sec
- ⇒ Recipes: up to 50 (depends on the size of each recipe)
- ⇒ Segments: max. 24 segments
- ⇒ Dosing-system:
 - a) Dispensumpump SP-177 for viscosities up to 800cps. incl. suck back function
 - b) Autom. cartridge dispense system 50ml Glass syringe incl. back function
- ⇒ Splash-collar process chamber:
 - 1) anodised aluminium (standard)
 - 2) splash-collar made of PE (Set of 10pcs. included)

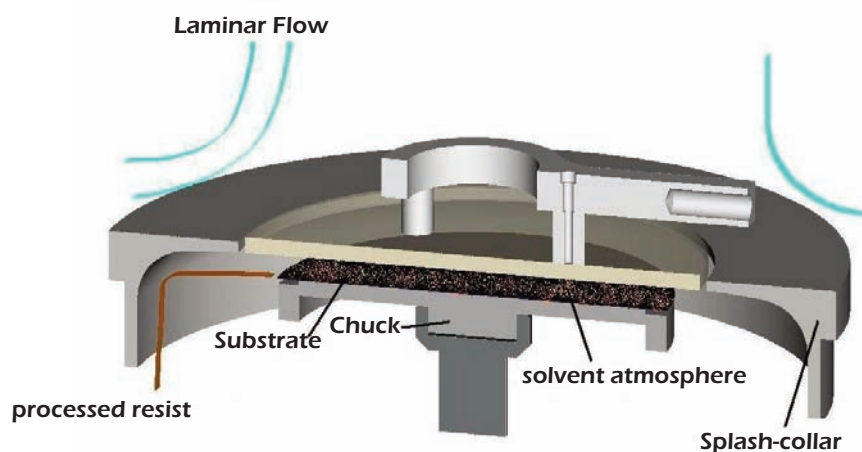

Closed process chamber with solvent atmosphere

- ⇒ 240VAC 50/60Hz 15A
- ⇒ Plugconnector for foot switch
- ⇒ Technical vacuum, tube Ø6/4mm (-0.8bar)
- ⇒ Compressed air, tube Ø6/4mm (6bar)
- ⇒ Exhaust-connector Ø76mm (40-60m³/h)

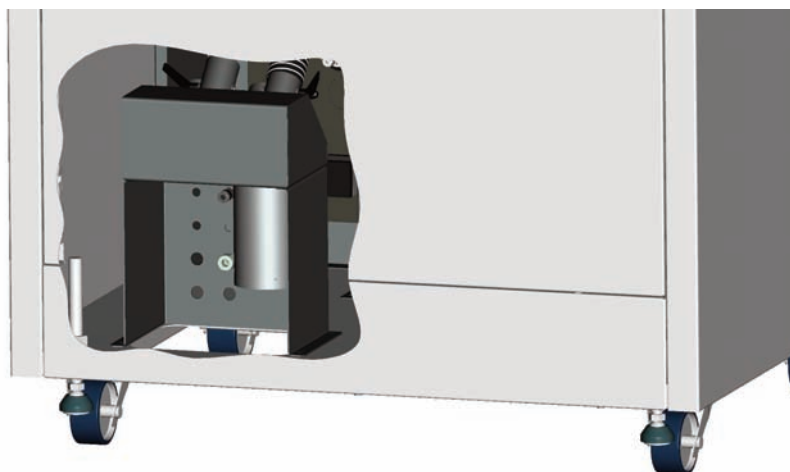

For further information please contact our sales-department: sales@sawatec.com

Pictures may show standards with options.

REQUIRED MEDIA

Tel: +423 377 17 90
Fax: +423 377 17 91
sales@sawatec.com
www.sawatec.com

SAWATEC AG
Industriestrasse 56
Postfach 514
FL-9491 Ruggell

VIEWS

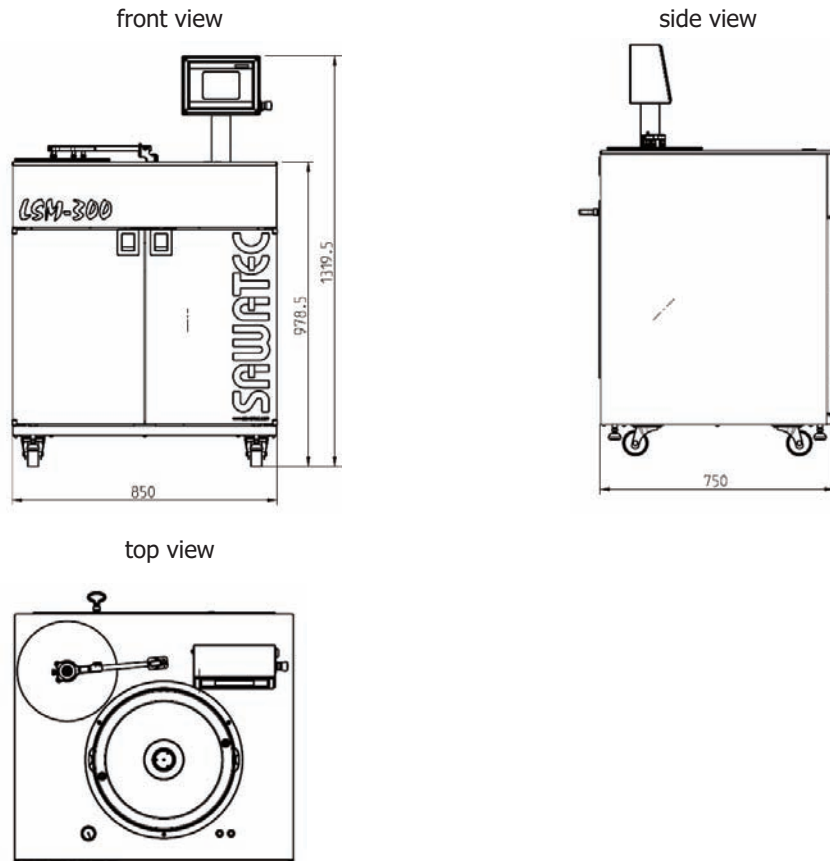

DIMENSIONS

- ⇒ Size: 850x750x980mm (LxBxH)
- ⇒ Weight: approx. 130kg

DESIGN

- ⇒ Housing: Stainless steel
- ⇒ Processbowl: anodised aluminium
- ⇒ Splash-collar: anodised aluminium (standard)
- ⇒ Lid: glass

DEALER

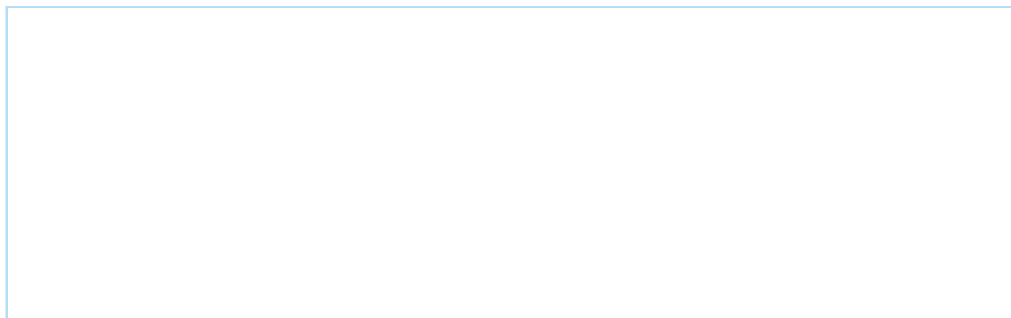

For further information please contact our sales-department: sales@sawatec.com
 Pictures may show standards with options.

Tel: +423 377 17 90
 Fax: +423 377 17 91
sales@sawatec.com
www.sawatec.com

SAWATEC AG
 Industriestrasse 56
 Postfach 514
 FL-9491 Ruggell